

## 3.4 PEDIGREES

*By Luke Zappia*

When you get up, the graffiti is gone. Someone has painted over it entirely. The rain has also stopped. Now it's blowing a gale. *Bloody Melbourne weather*, you think. You walk absent-mindedly along South Lawn, trying to get your head together. You stop a passing student and enquire, as casually as possible, what day it is. She tells you that it is Wednesday and hands you a flyer for a trampoline sale on the roof of the Old Arts building on Friday afternoon. It seems a strange place for a trampoline sale. But, then again, there's a lot of strange stuff going on. What looks like a man flies overhead and lands on the clocktower with a loud *Gong*.

"Oooooo-K," you tell yourself, "it's all going to be OK. A little innocent brick has just damaged a complicated piece of machinery, turning it into what seems to be an unpredictable time machine. You jumped ahead to Tuesday and now you're at Wednesday. That's fine. You've only lost two days. All you have to do is get rid of this machine, call in a couple of retrospective sick days and everything will go back to normal."

Somewhat reassured, you descend the stairs near the John Medley building and make your way into the underground carpark where that scene from *Mad Max* was filmed. It seems like a fitting location to destroy a wayward time machine. You sit the machine on the ground in an empty park and raise your boot to stomp out this situation for good.

"I'm afraid it's not that simple," a voice says in a Scottish accent.

You look up to see a thin, white, brunette British man wearing a bowtie and a big scarf and some Converse high tops, charging his police box at the electric car charging station in the corner.

"Who are you?" you ask.

"I'm Doctor Who," says the man.

"Not *The Doctor*?" you enquire.

"Nope," says Doctor Who, "my name is definitely Doctor Who."

"Well," you say, "that's going to rile up some nerds. Especially if I call you that in front of people who haven't heard that explanation yet. Now do you mind explaining what's going on?"

"Well," says Doctor Who, "you seem to have broken time."

He goes to his police box and fetches a large blackboard. On it are a series of tree diagrams.

"Let me explain it to you through a simple analogy," he says, beginning to erase the diagrams. But something about the diagrams catches your eye. You try to memorise them before they are erased. But then, The Device shakes, gives a squeal and everything goes black again.



A

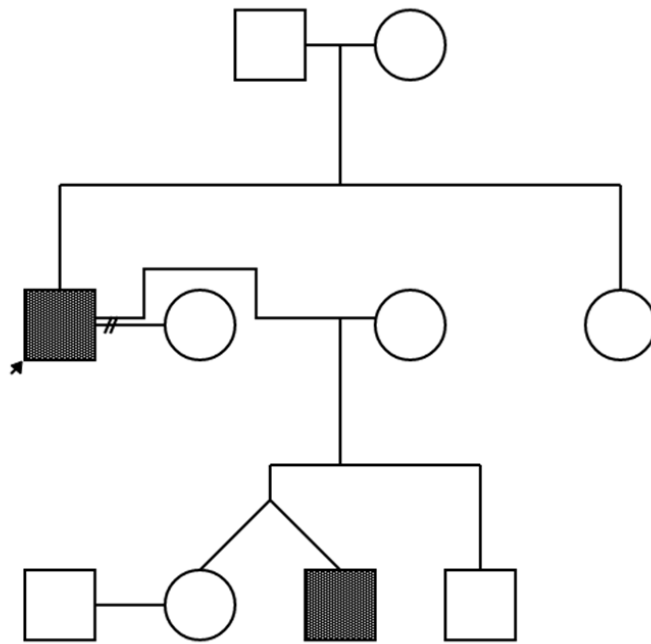

B

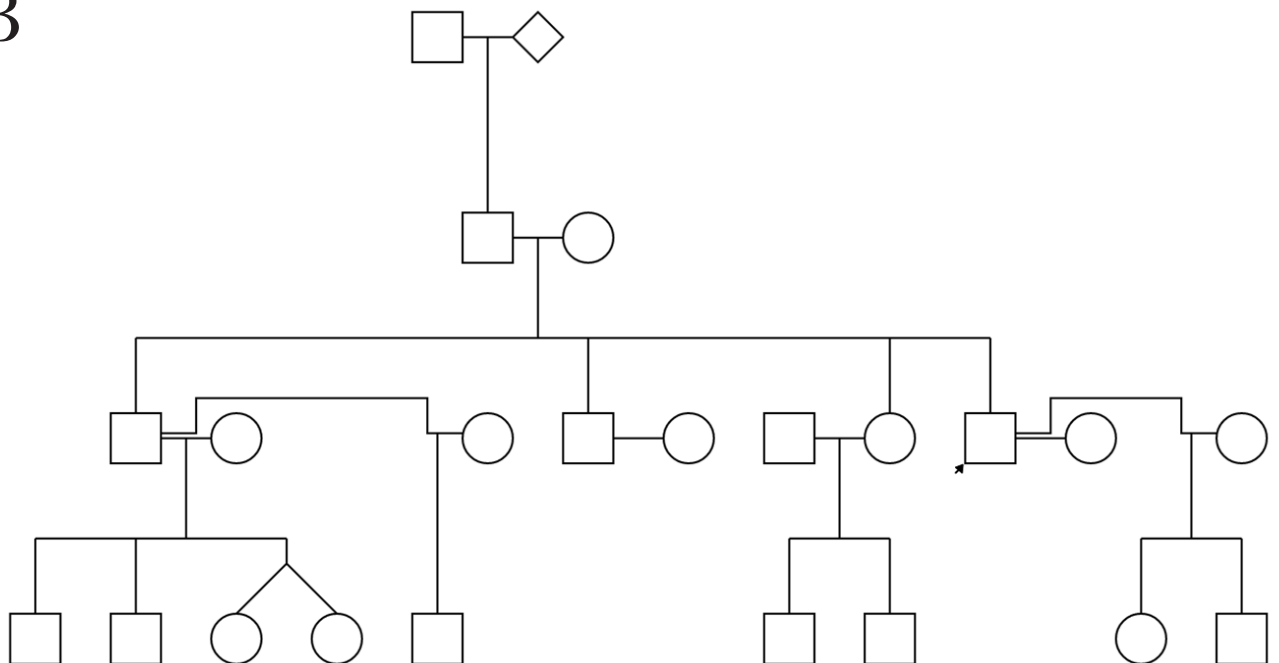

C

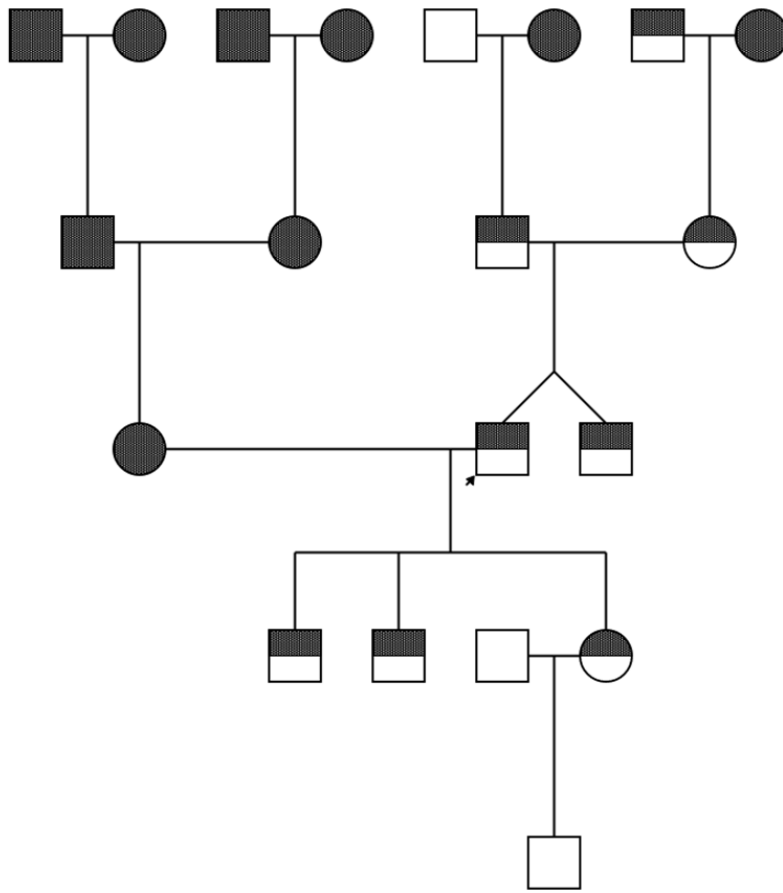

D

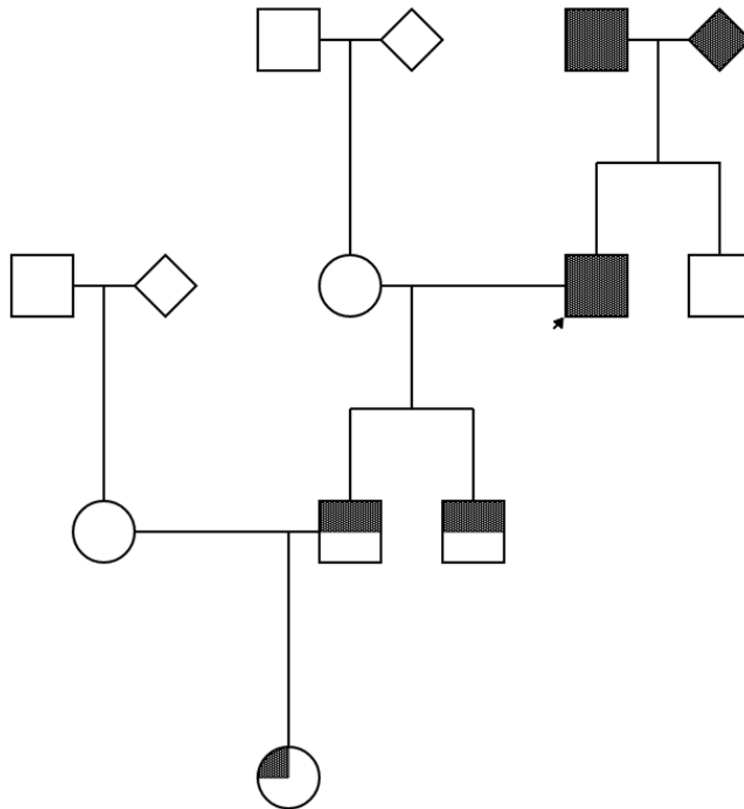

E

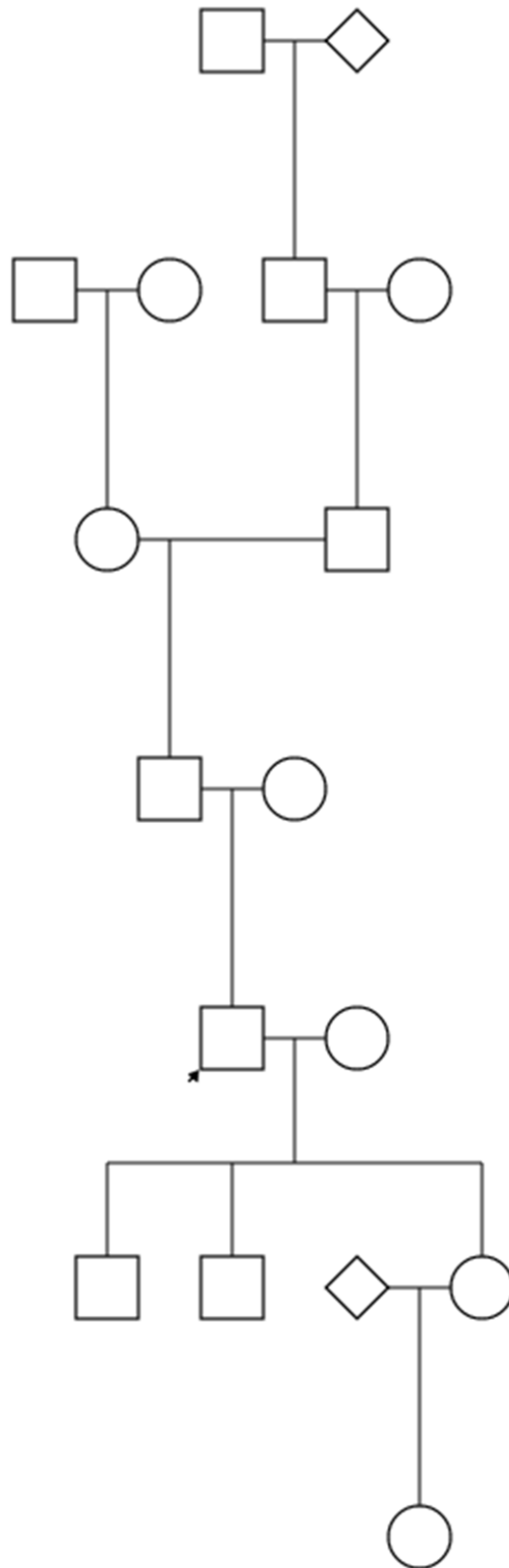

F

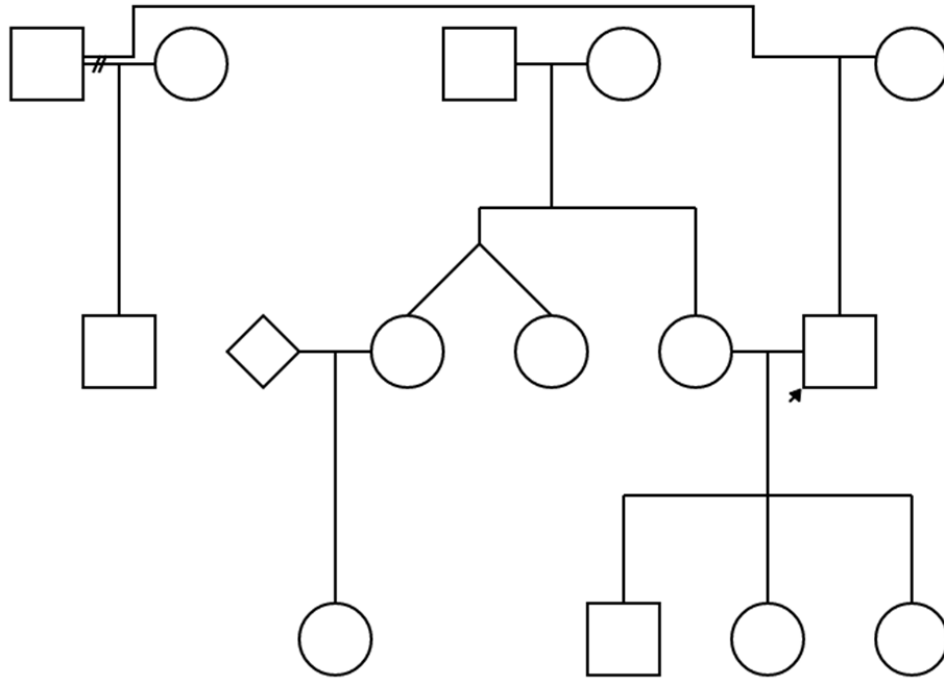

G

